

# malabrigo

BOOK 18 Rios & Washted - Interchangeable Yarns

## Rahi



Photographs by Rose Callahan

\*For all pattern-related inquiries please visit [www.malabrigoyarn.com](http://www.malabrigoyarn.com)

Text and photograph copyrights © by Malabrigo Yarn, Montevideo, Uruguay.

All rights reserved. Individual, non-commercial use only. Sale, any other commercial use and any reproduction, publication or distribution prohibited.

[www.malabrigoyarn.com](http://www.malabrigoyarn.com)

# malabrigo

## BOOK 18 Rios & Washted - Interchangeable Yarns

### Rahi

designed by Sarah Hatton

Three-quarter sleeve cardigan

**SKILL LEVEL**  **INTERMEDIATE**

#### SIZES

Sized for Small, Medium, Large, 1X, 2X and 3X. Shown in size Small.

#### MATERIALS

*Washted* by Malabrigo, 3½oz/100g hanks, each approx 210yd/192m (superwash merino wool)

- 5 (5, 6, 7, 7, 8) hanks in #096 Sunset

#### NEEDLES

- One each sizes 6 and 8 (4 and 5mm) circular needles each 32"/80cm long, OR SIZE TO OBTAIN GAUGE

#### NOTIONS

- Stitch holders
- Seven 1"/25mm buttons

#### MEASUREMENTS

- Bust 37 (41½, 46, 50½, 54¾, 59¼)"/94 (105.5, 117, 128, 139, 150.5)cm
- Length 20¼ (20¾, 22, 22½, 23¾, 24¼)"/51.5 (52.5, 56, 57, 60.5, 61.5)cm
- Upper arm 17 (17, 17½, 17½, 18, 18)"/43 (43, 44.5, 44.5, 45.5, 45.5)cm

#### GAUGE

18 sts and 26 rows = 4"/10cm over St st using size 8 (5mm) needles.  
TAKE TIME TO CHECK YOUR GAUGE.

#### NOTES

- 1) Body is worked in one piece to the underarm, then fronts and back are worked separately to shoulder.
- 2) Button band is approximately 1"/2.5cm wide.
- 3) Texture pat increases st count for several rows, sts are decreased back to original count at end of each texture band.

#### BACK

With smaller needle, cast on 161 (181, 201, 221, 241, 261) sts.

**ROW 1 (RS)** P1, \*k1, p1; rep from \* to end.

**ROW 2 (WS)** K1, \*p1, k1; rep from \* to end.

Rep last 2 rows for k1, p1 rib for 1½"/4cm, end with a WS row.

Knit 2 rows, inc 1 st at end of last row—162 (182, 202, 222, 242, 262) sts.

Change to larger needles.

#### BEG TEXTURE PATTERN

**ROW 1 (RS)** P3, \*(k1, yo, k1, yo, k1) into next st, p4; rep from \* to last 4 sts, (k1, yo, k1, yo, k1) in next st, p3.

**ROW 2** K3, p5, \*k4, p5; rep from \* to last 3 sts, k3.

**ROW 3** P3, \*k5, p4; rep from \* to last 8 sts, k5, p3.

**ROW 4** Rep row 2.

**ROW 5** P3, \*SKP, k1, k2tog, p4; rep from \* to last 8 sts, SKP, k1, k2tog, p3.

**ROW 6** K3, p3, \*k4, p3; rep from \* to last 3 sts, k3.

**ROW 7** P3, \*SK2P, p4; rep from \* to last 6 sts, SK2P, p3.

**ROWS 8–11** Knit.

**ROW 12** \*P1, k1; rep from \* to end.

**ROWS 13–16** Word in k1, p1 rib as established.

**ROWS 17–20** Knit.

**ROW 21** P3, \*(k1, yo, k1) into next st, p4; rep from \* to last 4 sts, (k1, yo, k1) in next st, p3.

**ROW 22** K3, p3, \*k4, p3; rep from \* to last 3 sts, k3.

**ROW 23** P3, \*k3, p4; rep from \* to last 6 sts, k3, p3.

Row 24 Rep row 22.

**ROW 25** P3, \*SK2P, p4; rep from \* to last 6 sts, SK2P, p3.

Rep rows 8–25 once more.

**NEXT 3 ROWS** Knit.

Begin with a RS row, cont in St st (k on RS, p on WS) until piece measures 13¾ (13¾, 14¼, 14¼, 14¾, 14¾)"/35 (35, 36, 36, 37.5, 37.5)cm from beg, end with a WS row.

#### DIVIDE FRONTS AND BACK

**NEXT ROW (RS)** K35 (39, 44, 49, 53, 58), bind off 10 (12, 12, 12, 14, 14) sts, k until there are 72 (80, 90, 100, 108, 118) sts on needle for back, bind off 10 (12, 12, 12, 14, 14) sts, k to end.

Turn and continue over 35 (39, 44, 49, 53, 58) left front sts only as foll, leaving rem sts on hold:

#### FOR SIZES LARGE, 1X, 2X AND 3X ONLY

**NEXT ROW (WS)** Purl.

**RAGLAN DEC ROW 1 (RS)** K2, SK2P, k to end—2 sts dec'd.

Rep last 2 rows 2 (4, 5, 7) times more—38 (39, 41, 42) sts.

#### FOR ALL SIZES

**NEXT ROW (WS)** Purl.

**RAGLAN DEC ROW 2 (RS)** K2, SKP, k to end—1 st dec'd.

Rep last 2 rows 14 (16, 15, 15, 16, 16) times more—20 (22, 22, 23, 24, 25) sts.

#### NECK SHAPING

**NEXT ROW (WS)** Bind off 6 (8, 8, 9, 10, 11) sts, p to end—14 sts.

Work raglan dec row 2 as before 5 times more, AT SAME TIME, dec 1 st at neck edge every row 3 times, then every other row 3 times—3 sts.

Work 1 WS row.

**NEXT ROW (RS)** K1, SKP—2 sts.

**NEXT ROW (WS)** P2.

Leave 2 sts on st holder or safety pin.

#### BACK

Join yarn to 72 (80, 90, 100, 108, 118) back sts ready to work a WS row.

\*For all pattern-related inquiries please visit [www.malabrigoyarn.com](http://www.malabrigoyarn.com)

# malabrigo

## BOOK 18 Rios & Washted - Interchangeable Yarns Rahi

FOR SIZES LARGE, 1X, 2X AND 3X ONLY

**NEXT ROW (WS)** Purl.

**RAGLAN DEC ROW 1 (RS)** K2, SK2P, k to last 5 sts, k3tog, k2—4 sts dec'd.

Rep last 2 rows 2 (5, 6, 9) times more—78 (76, 80, 78) sts.

FOR ALL SIZES

**NEXT ROW (WS)** Purl.

**RAGLAN DEC ROW (RS)** K2, SKP, k to last 4 sts, k2tog, k2—2 sts dec'd.

Rep last 2 rows 19 (21, 20, 19, 20, 19) times more—32 (36, 36, 36, 38, 38) sts.

Purl 1 row. Bind off.

### RIGHT FRONT

Join yarn to 35 (39, 44, 49, 53, 58) right front sts ready to work a WS row.

FOR SIZES LARGE, 1X, 2X AND 3X ONLY

**NEXT ROW (WS)** Purl.

**RAGLAN DEC ROW 1 (RS)** K to last 5 sts, k3tog, k2—2 sts dec'd.

Rep last 2 rows 2 (4, 5, 7) times more—38 (39, 41, 42) sts.

FOR ALL SIZES

**NEXT ROW (WS)** Purl.

**RAGLAN DEC ROW 2 (RS)** K to last 4 sts, k2tog, k2—1 st dec'd.

Rep last 2 rows 13 (15, 14, 14, 15, 15) times more, work 1 WS row—21 (23, 23, 24, 25, 26) sts.

### NECK SHAPING

**NEXT ROW (RS)** Bind off 6 (8, 8, 9, 10, 11) sts, k to last 2 sts, k2tog, k2—14 sts.

Work raglan dec row 2 as before 5 times more, AT SAME TIME, dec 1 st at neck edge every row 3 times, then every other row 3 times—3 sts. Work 1 WS row.

**NEXT ROW (RS)** K2tog, k1—2 sts.

**NEXT ROW (WS)** P2.

Leave 2 sts on st holder or safety pin.

### SLEEVES

With smaller needles, cast on 67 sts.

**ROW 1 (RS)** K1, \*p1, k1; rep from \* to end.

**ROW 2 (WS)** P1, \*k1, p1; rep from \* to end.

Rep last 2 rows for k1, p1 rib for 1¼"/3cm, end with a WS row.

Change to larger needles.

### BEG TEXTURE PAT

Knit 4 rows.

**ROW 1** P3, \*(k1, yo, k1) into next st, p4; rep from \* to last 4 sts, (k1, yo, k1) in next st, p3.

**ROW 2** K3, p3, \*k4, p3; rep from \* to last 3 sts, k3.

**ROW 3** P3, \*k3, p4; rep from \* to last 6 sts, k3, p3.

**ROW 4** Rep row 2.

**ROW 5** P3, \*SK2P, p4; rep from \* to last 6 sts, SK2P, p3.

Knit 3 rows.

Beg with a RS row, work in St st for 2 rows.

**INC ROW (RS)** K1, M1, k to last st, M1, k1—2 sts inc'd.

Cont in St st, rep inc row every 10th (10th, 10th, 10th, 8th, 8th) row 4 (4, 5, 5, 6, 6) times—77 (77, 79, 79, 81, 81) sts.

Work even until piece measures 12½"/31.5cm, end with a WS row.

### RAGLAN CAP SHAPING

Bind off 5 (6, 6, 6, 7, 7) sts at beg of next 2 rows—67 (65, 67, 67, 67, 67) sts.

FOR SIZES SMALL, MEDIUM AND LARGE ONLY

**RAGLAN DEC ROW 1 (RS)** K2, SKP, k to last 4 sts, k2tog, k2—2 sts dec'd.

**RAGLAN DEC ROW 2 (WS)** P2, p2tog, p to last 4 sts, p2tog tbl, p2—2 sts dec'd.

Rep last 2 rows 4 (1, 0) times more, then rep raglan dec row 1 on next row, then every other row 15 (20, 23) times more—15 sts. Work 1 WS row. Bind off.

FOR SIZES 1X, 2X AND 3X ONLY

**RAGLAN DEC ROW 1 (RS)** K2, SKP, k to last 4 sts, k2tog, k2—2 sts dec'd.

Rep raglan dec row every 4th row 0 (3, 5) times, then every other row 25 (22, 20) times more—15 sts. Work 1 WS row. Bind off.

### FINISHING

Block pieces lightly to measurements. Sew raglan and underarm seams.

Sew sleeve seams.

### NECKBAND

With RS facing and smaller needle, beg at right front neck edge, pick up and k 14 (16, 16, 17, 18, 19) sts along right front neck edge including 2 from holder, 15 sts along right sleeve top, 31 (35, 35, 35, 37, 37) sts along back neck edge, 15 sts along left sleeve top, 14 (16, 16, 17, 18, 19) sts along left front neck edge including 2 from holder—89 (97, 97, 99, 103, 105) sts.

**NEXT ROW (WS)** K1, \*p1, k1; rep from \* to end.

Cont in k1, p1 as established for 6 rows more.

Bind off in rib.

### BUTTON BAND

With RS facing and smaller needle, beg at left front neck edge, pick up and k 111 (114, 122, 124, 132, 134) sts along left front edge.

**ROW 1 (WS)** K1, \*p1, k1; rep from \* to end.

**ROW 2 (RS)** K1, \*k1, p1; rep from \* to last 2 sts, k2.

Rep last 2 rows twice more, then work row 1 once more. Bind off in rib.

### BUTTONHOLE BAND

With RS facing and smaller needle, beg at lower right front edge, pick up and k 111 (114, 122, 124, 132, 134) sts along right front edge.

**ROW 1 (WS)** K1, \*p1, k1; rep from \* to end.

**ROW 2 (RS)** K1, \*k1, p1; rep from \* to last 2 sts, k2.

**NEXT ROW (WS)** Rib 3 (4, 3, 4, 4, 3), [bind off 2 sts (1 st is on RH needle), rib 14 (14, 16, 16, 17, 18)] 6 times, bind off 2 sts, rib to end.

**NEXT ROW** Work in rib as established, casting on 2 sts over each bound-off section. Work 3 rows more in rib as established. Bind off in rib. Sew buttons to buttonband to correspond to buttonholes. ♦

# malabrigo

BOOK 18 Rios & Washted - Interchangeable Yarns  
Rahi

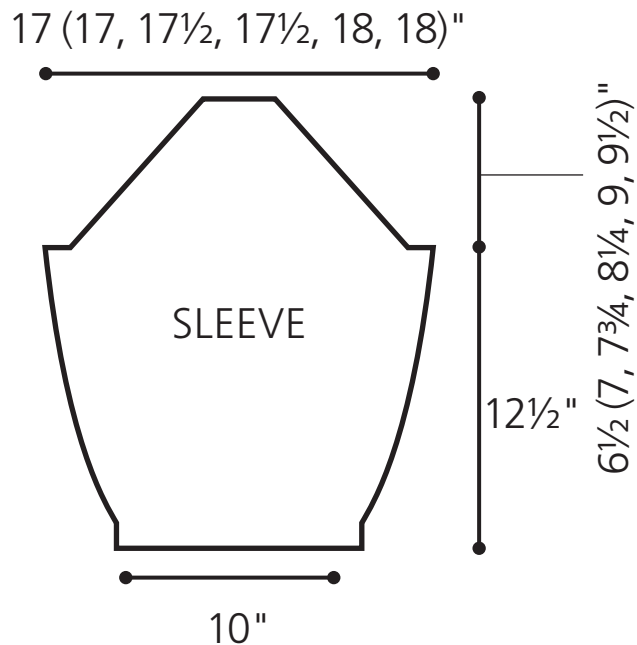
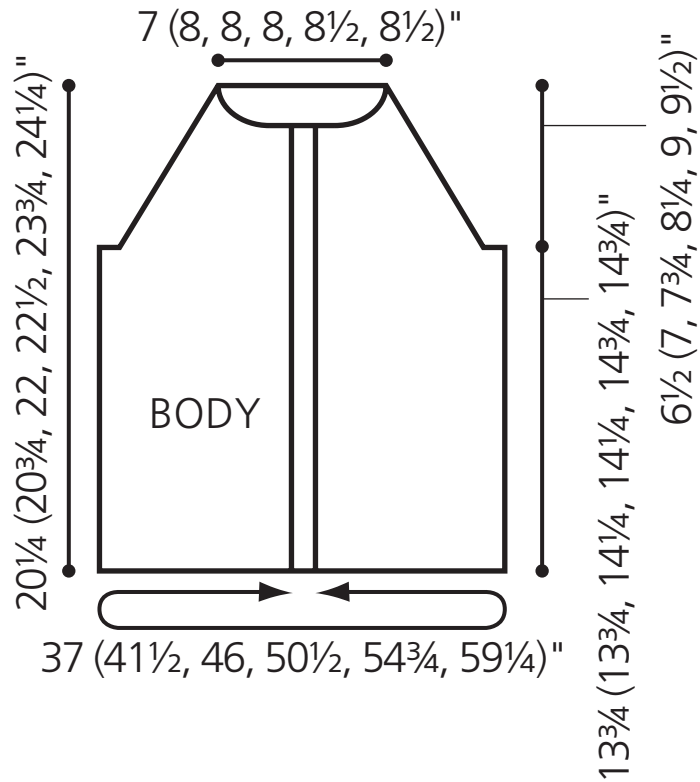

\*For all pattern-related inquiries please visit [www.malabrigoyarn.com](http://www.malabrigoyarn.com)

Text and photograph copyrights © by Malabrigo Yarn, Montevideo, Uruguay.

All rights reserved. Individual, non-commercial use only. Sale, any other commercial use and any reproduction, publication or distribution prohibited.

[www.malabrigoyarn.com](http://www.malabrigoyarn.com)

# malabrigo

BOOK 18 Rios & Washted - Interchangeable Yarns

## Abbreviations & Glossary

### KNIT Abbreviations

**approx** approximately  
**beg** begin(ning)  
**CC** contrast color  
**cn** cable needle  
**cm** centimeter(s)  
**cont** continue(ing)  
**dec** decrease(ing)  
**dpn** double-pointed needle(s)  
**follow** follow(s)(ing)  
**g** gram(s)  
**inc** increase(ing)  
**k** knit  
**k2tog** knit two stitches together  
**k3tog** knit three stitches together  
**kfb** knit into front and back of stitch  
**LH** left-hand  
**M1** make one (see Glossary)  
**M1p** Make 1 purl (see Glossary)  
**MC** main color  
**m** meter(s)  
**mm** millimeter(s)  
**oz** ounce(s)  
**p** purl  
**p2tog** purl two stitches together  
**pat(s)** pattern(s)  
**pm** place marker  
**rem** remain(s)(ing)  
**rep** repeat  
**RH** right-hand  
**rnd(s)** round(s)  
**RS** right side  
**SKP** see Glossary  
**SK2P** see Glossary  
**S2KP** see Glossary  
**sl** slip  
**sl st** slip stitch  
**sm** slip marker  
**ssk** slip, slip, knit (see Glossary)  
**st(s)** stitch(es)  
**St st** stockinette stitch (see Glossary)  
**tbl** through back loop  
**tog** together  
**WS** wrong side  
**wyib** with yarn in back  
**wyif** with yarn in front  
**yd(s)** yard(s)  
**yo** yarn over  
\* repeat directions following \* as many times as indicated  
[ ] repeat directions inside brackets as many times as indicate

### Crochet Abbreviations

**ch** chain  
**sl st** slip stitch  
**sc** single crochet  
**hdc** half-double crochet  
**dc** double crochet  
**tr** treble crochet

### Glossary

**Garner stitch** Knit every row. For circular knitting: Alternate knit one round, purl one round.  
**Make one (M1)** Insert tip of LH needle from front to back under the strand between the last stitch worked and the next stitch on the needle. Knit into the back loop—1 knit stitch increased.  
**Make 1 stitch purl (M1p)** Insert the left needle from back to front into the running thread between the stitches on the right and left needle. Purl this stitch through the front loop in order to twist the stitch—1 purl stitch increased.  
**SKP** Slip 1, knit 1, pass slip stitch over knit 1—1 stitch decreased.  
**SK2P** Slip 1, knit 2 stitches together, pass slip stitch over k2tog—2 stitches decreased.  
**S2KP** Slip next 2 sts as if to k2tog, k1, pass the 2 slipped sts over the k1—2 stitches decreased.  
**ssk** Slip next two sts knitwise, one at a time, to right-hand needle. Insert tip of left-hand needle into fronts of these stitches from left to right and knit them together—1 stitch decreased.  
**St st** Knit right-side rows and purl wrong-side rows. For circular knitting: Knit all rounds.

### Knitting Needles\*

U.S.	METRIC
0	2mm
1	2.25mm
2	2.75mm
3	3.25mm
4	3.5mm
5	3.75mm
6	4mm
7	4.5mm
8	5mm
9	5.5mm
10	6mm
10½	6.5mm
11	8mm
13	9mm
15	10mm
17	12.75mm
19	15mm
35	19mm

**\*Note** The needle sizes used in this book vary, based on the design and desired drape of the fabric. They may be different than the suggested needle size on the ball band. To achieve the look of the pictured garment, always make a gauge swatch and change the needle size to obtain the gauge given at the beginning of the instructions.

\*For all pattern-related inquiries please visit [www.malabrigoyarn.com](http://www.malabrigoyarn.com)

# malabrigo

BOOK 18 Rios & Washted - Interchangeable Yarns  
Rahi



\*For all pattern-related inquiries please visit [www.malabrigoyarn.com](http://www.malabrigoyarn.com)

Text and photograph copyrights © by Malabrigo Yarn, Montevideo, Uruguay.

All rights reserved. Individual, non-commercial use only. Sale, any other commercial use and any reproduction, publication or distribution prohibited.

[www.malabrigoyarn.com](http://www.malabrigoyarn.com)

# malabrigo

BOOK 18 Rios & Washted - Interchangeable Yarns  
Rahi



# malabrigo

BOOK 18 Rios & Washted - Interchangeable Yarns  
Rahi



# malabrigo

## About us

Malabrigo is a family-owned yarn company located in Uruguay. We are known for our hand-dyed yarns of incredible softness and wonderful color variations. Our products are made out of the softest fibers available and are inspired by nature, landscapes, places, art and everyday life. And that is what we try to represent in the names of our 17 different yarns and more than 300 colors.

We produce yarn because we are passionate about it. We believe in the pleasure of knitting with good-quality, carefully designed, subtly painted yarns and in the joy of wearing whatever is made out of them.

Our wish is to continue developing yarns and colors to inspire people around the world—and to be inspired by them in return.

## History

Malabrigo started small, when two brothers-in-law started dyeing wool in a kitchen back in 2005. After achieving some good results, they started selling a few skeins to the U.S., and before they knew it, they had quickly grown to other countries in Europe and the rest of the world. To keep up with this growth, they needed to relocate to larger facilities and hire more employees.

This resulted in Malabrigo's mill, which is located at Parque Tecnológico Industrial del Cerro, a technology and industry park in Montevideo, Uruguay, where yarns are dyed and packed in large rooms with natural light.

In 2010 the factory added a flat-plate thermal heating system to decrease the environmental footprint. Using the power of the sun, the water tanks are heated for the various processes to make your favorite yarns. The company employs environmentally safe practices that use as little water and as few chemicals as possible.

More recently, the company added a new mill in Perú.

Malabrigo employs mostly women and always tries to provide jobs to people who historically have been given fewer opportunities.

## Fibers

Most Malabrigo yarns are made with 100% Uruguayan merino wool. Uruguay has one of the biggest wool supplies in the world and produces a very, very good wool with regards to softness.

Our wool is 100% produced by Uruguayan farms that allow their sheep to go free-range through the hills and are herded by actual old-style shepherds. The controversial practice of mulesing does not exist in Uruguay.

Some of our yarns use other fibers, such as Aquarella and Gruesa (100% Uruguayan Corriedale wool) or Silky Merino (a blend of our merino and top-quality silk) and Silkpaca (baby alpaca from Perú and top-quality silk). We always ensure that our materials come from the best suppliers we can find around the world.

## Malabrigo flock

We are pleased to announce that Malabrigo is the proud owner of a flock of merino and Corriedale sheep, who live on a ranch near our headquarters in Montevideo. Taking this step has been very important to us: We strive for sustainability and quality in all aspects of our business, and now we are able to have a direct hand in wool production from the very first step, and to ensure the humane, high-quality care of our happy little sheep. True, this flock isn't enough to produce all of our yarn by a long shot—but they are awfully cute. Welcome to the family, little guys! Should you happen to be in the Montevideo area, we invite you to visit our little sheepfold and say hello to the flock!

In the following video we show you around beautiful Piedras de Afilas and demonstrate the process by which we shear our sheep and harvest the beautiful fleece that becomes Malabrigo yarn. We strive to use sustainable and humane farming practices with our ranch and flock. Happy sheep make the best wool!

<https://www.youtube.com/watch?v=MogPKXf5-Lk>

## Our Commitment to Sustainability

As part of our ongoing effort to build a greener business, our Superwash manufacturing process now meets Oeko-Tex standards. This means our yarn is free from a range of harmful substances often found in manufacturing (such as formaldehyde, pesticides, heavy metals and a variety of other toxins and carcinogens.)

In 2010 the factory added a flat-plate thermal heating system to decrease our environmental footprint. Using the power of the sun, the water tanks are heated for the various processes to make Malabrigo yarns. The company employs environmentally safe practices using as little water and as few chemicals as possible.

# malabrigo

## Washted

A superwash version of the classic Worsted Merino base. While remaining true to the original softness of worsted, we 'washed it' so you can too, allowing more freedom and ease of care. Having the same weight as Worsted, it can be used interchangeably for any projects you may have planned for Worsted. Like all our yarns, it is kettle-dyed in small batches by our artisan dyers and is full of subtle variation and beauty.

**Great for:** Accessories and garments, next-to-skin wear, cables, textured stitches, color-work, anything where warmth and comfort are a factor!

Be sure to get enough yarn to complete your project since each bag is a different dye lot, and skeins may vary from bag to bag. Skeins may vary one from the other even within the same bag. To ensure random color distribution, work from two balls of yarn at once, alternating a few rows from each ball.

**Weight** Worsted

**Texture** Single Ply

**Yardage/Meters** 210 yards (192 meters)

**Skein weight** 100 grams (3.53 ounces)

**Content** 100% Superwash Merino Wool

**Gauge** 18 sts = 4 inches

**Recommended needle size** US 7 - 9 or 4.5 - 5.5mm

**Recommended hook size** US I-9 to K-10/12 or 5.5-6.5 mm

**Care** Machine washable, gentle cycle, cold water. Do not tumble. Dry flat.

For retailers stocking Malabrigo yarns please visit <http://malabrigoyarn.com>



Aguas  
WD855



Aniversario  
WD005



Archangel  
WD850



Arco Iris  
WD866



Arcobaleno  
WD748



Azules  
WD856



Camaleón  
WD684



Candombe  
WD870

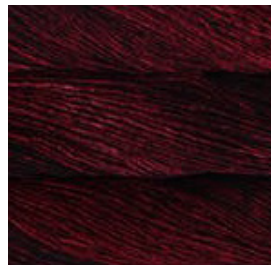

Cereza  
WD033



Cirrus Gray  
WD845



Cowboy  
WD215



Diana  
WD886



English Rose  
WD057



Fortaleza  
WD722



Heirloom Vegetables  
WD746

\*For all pattern-related inquiries please visit [www.malabrigoyarn.com](http://www.malabrigoyarn.com)

Text and photograph copyrights © by Malabrigo Yarn, Montevideo, Uruguay.

All rights reserved. Individual, non-commercial use only. Sale, any other commercial use and any reproduction, publication or distribution prohibited.

[www.malabrigoyarn.com](http://www.malabrigoyarn.com)

# malabrigo

Washed color card

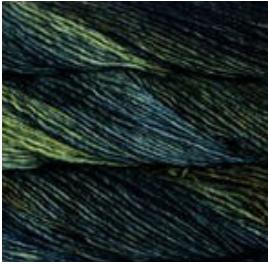

Hojas  
WD880



Indiecita  
WD416



Indonesia  
WD723



Natural  
WD063



Pearl  
WD036



Piedras  
WD862



Plomo  
WD043



Poción  
WD139



Selva Peruana  
WD749



Sunset  
WD096



Whale's Road  
WD247

\*For all pattern-related inquiries please visit [www.malabrigoyarn.com](http://www.malabrigoyarn.com)

Text and photograph copyrights © by Malabrigo Yarn, Montevideo, Uruguay.  
All rights reserved. Individual, non-commercial use only. Sale, any other commercial use and any reproduction, publication or distribution prohibited.  
[www.malabrigoyarn.com](http://www.malabrigoyarn.com)